

# Construction Drawing: 1"=8' Scale

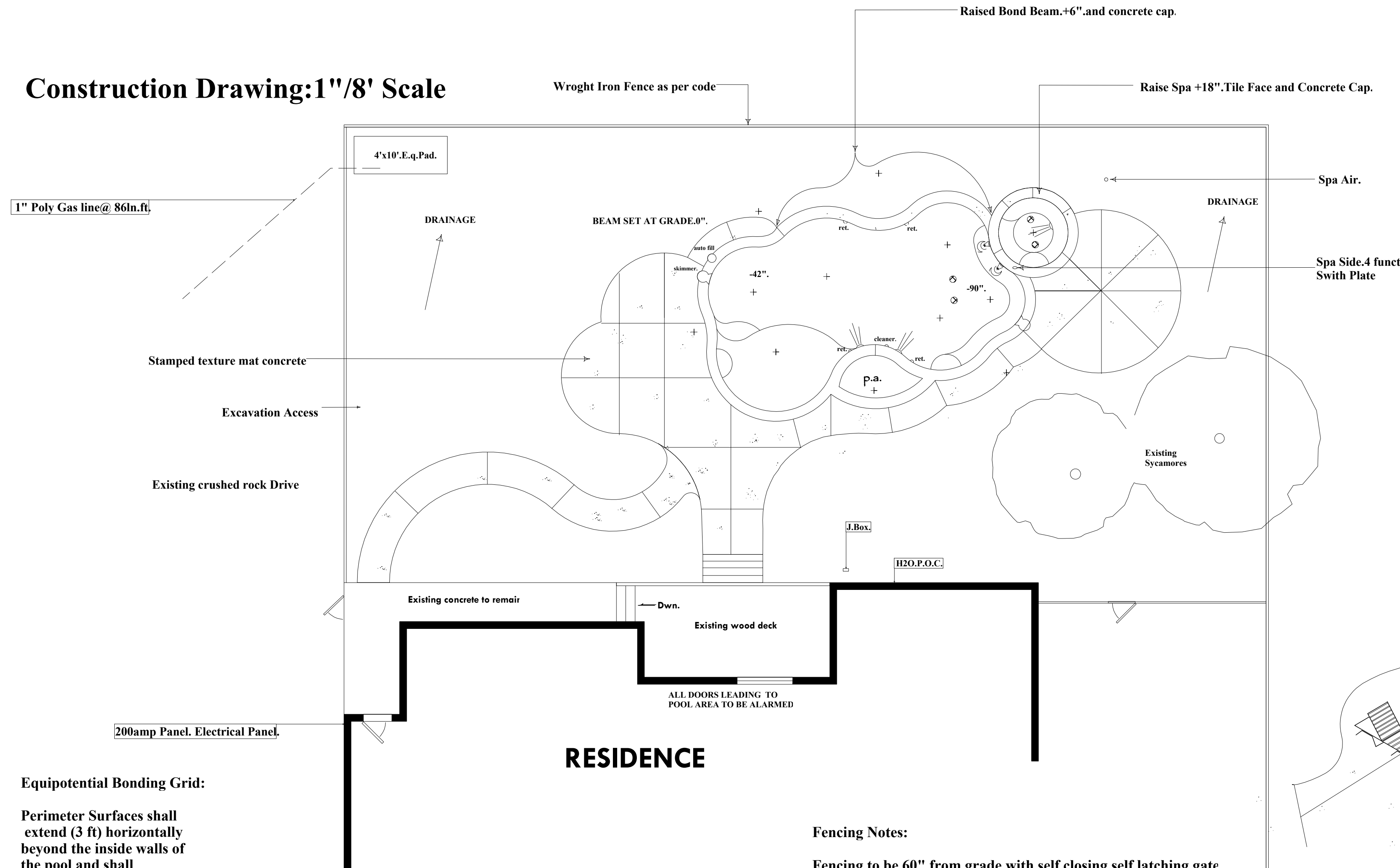

### Equipotential Bonding Grid:

Perimeter Surfaces shall extend (3 ft) horizontally beyond the inside walls of the pool and shall include unpaved surfaces as well as poured concrete and other types of paving. Note: reinforcing steel and copper conductor grids are attached to the pool structure, at minimum of (4) points uniformly spaced around the perimeter of the pool

## RESIDENCE

### Fencing Notes:

Fencing to be 60" from grade with self closing, self latching gate Gate to be no less than 54" from grade and must swing outward from pool area. No hand holds or footholds on fence & no gaps greater than four inches.

### SPA DETAIL: 1/4"

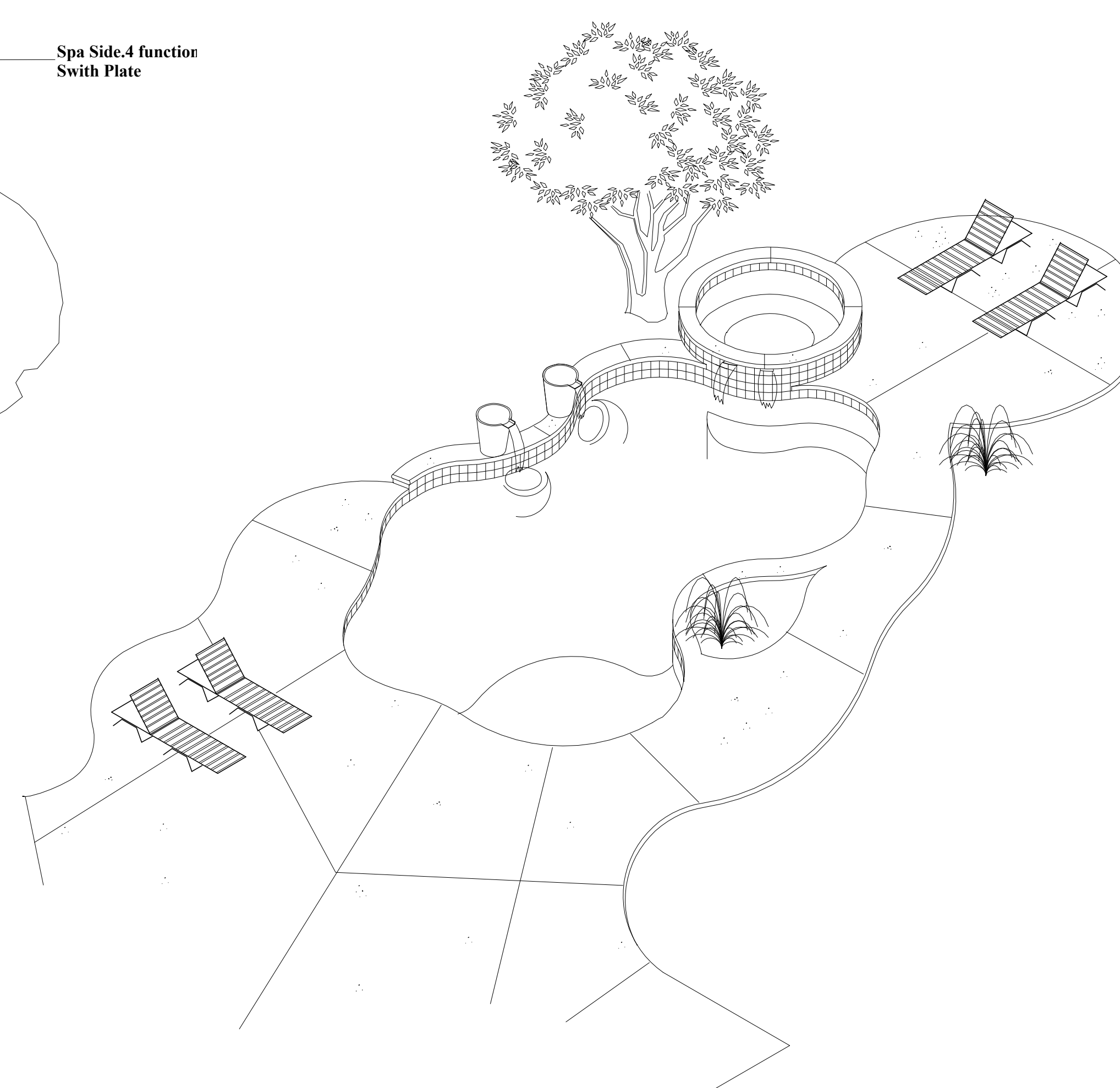
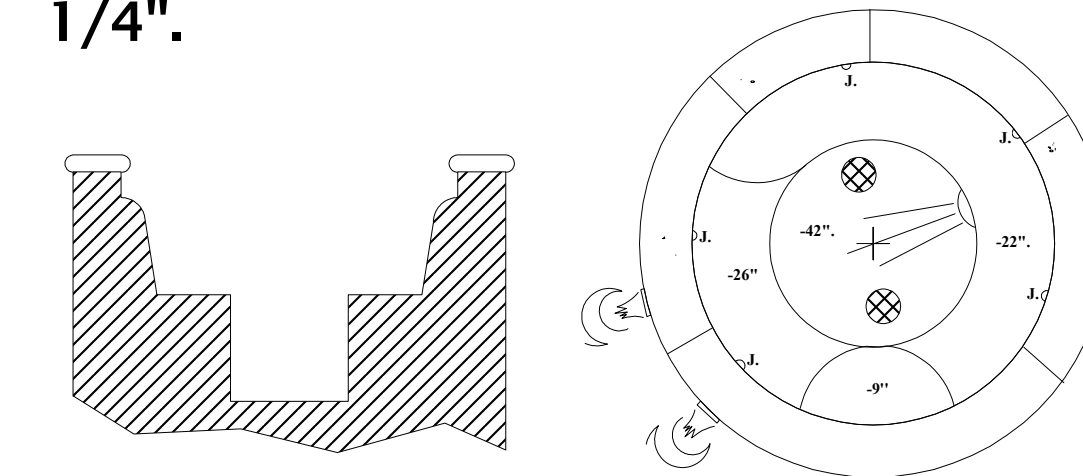

Les. Bedingfield.  
Rendition Only.

GENERAL POOL SPECIFICATIONS:	
MAXIMUM LENGTH:	34.ft.2".
MAXIMUM WIDTH:	18.ft.2".
DEPTH:	3ft.6"x7ft.6".
POOL PERIMETER:	95.In.ft.
POOL SQUARE FTG.	500.sq.ft.
<b>EXCAVATION:</b>	
ACCESS:	Left Side.
EQUIPMENT USED:	Std. Excavator.
REMOVE SOIL:	Yes.
REMOVE STUMPS:	.N/A.
REMOVE FENCE:	.N/A.
REPLACE FENCE:	Wrought Iron Fence.as per plan.
REMOVE CONCRETE:	.N/A.
SAW CUT CONCRETE:	.N/A.
<b>STEEL:</b>	
STD.EXPANSIVE SOIL STEEL SCHEDULE	
<b>PLUMBING:</b>	
FILTER RUN:	40.In.ft.@2.1/2P.V.C.sch.40.
RETURNS:	x 4.
GAS LINE SIZE:	1".
W-FALL PLUMB:	.N/A.
VALVES:	Motorised Valves.
<b>ELECTRICAL:</b>	
FOOTAGE:	60.ft.
LIGHTS:	x2.Pentair.White L.E.D.
<b>GUNITE:</b>	
LOVE SEAT:	As per plane.
BENCHES:	As per plane.
CABO SHELF:	As per plane.
NOTCHED BEAM:	.N/A.
R.B.B. 6":	IN:X 25 LN.FT
R.B.B. N/A:	IN:X N/A LN.FT
R.B.B. N/A:	IN:X N/A LN.FT
<b>FASCIA TYPE:</b>	
TILE:	Std Waterline Tile.
STONE:	N/A.
OTHER:	N/A.
<b>DECKING:</b>	
SQ.FT:	850 Sq.ft.
TYPE:	Std Davis integral Color texture stamped.(T.B.D.)
DECCO DRAIN:	N/A.
CANTILEVERE:	Yes.with Band.
<b>COPING:</b>	
TYPE:	N/A. MASTIC: N/A. LN.FT.
<b>TILE:</b>	
WATERLINE TYPE	Std.(T.B.D.)
TRIM:	N/A.
<b>PLASTER:</b>	
COLOR:	Gemstone.(T.B.D.)
GEMSTONE:	COLOR:
RIVER ROC:	N/A. COLOR: N/A.
<b>ROCKWORK:</b>	
TYPE:	N/A.
WATERFALL:	N/A.
<b>SPA:</b>	
SIZE:	44.sq.ft. IN: 7ft OUT:
PLUMBING RUN:	74.In.ft.
DAM WALL LENGTH:	7.In.ft.
NUMBER OF JETS:	x 5
PUMP TYPE:	Shared Circulation Pump.
H.P.:	
SPA SIDE REMOTE:	4 function spa switch.
LIGHT:	x 1.
<b>EQUIPMENT:</b>	
FILTER TYPE:	Pentair Starite Mod med
SIZE:	400
PUMP TYPE:	Pentair Starite.vs 4x160
SIZE:	3 H.p
DEDICATED PUMP:	N/A.
CONTROLLERS:	Pentair Easy Touch 4.Wireless.
HEATER TYPE:	Pentair Sta Rite Mod 400K.B.T.U Heater.
OTHER:	Pentair Pressure Cleaner and Booster pump. Paramount U.V. Frog mineral pack..

PREPARED EXCLUSIVELY FOR:

NAME: \_\_\_\_\_

ADDRESS: \_\_\_\_\_

CITY: \_\_\_\_\_ ZIP: \_\_\_\_\_

APN #: \_\_\_\_\_

HOME PHONE: CELL PHONE: WORK PHONE: \_\_\_\_\_

SIGNATURE: \_\_\_\_\_

DATE: \_\_\_\_\_

**Majestic Builders.**

License# 581822.

11241 Caloma Rd  
Suite D  
Gold River.  
95760.

PLOT MAP:  
bk.123-07  
Sacramento County  
Parcel 1.

N.

NOTES.

Location.Map.

Revised Changes.
Permit Copy.(Final 10/01/15)

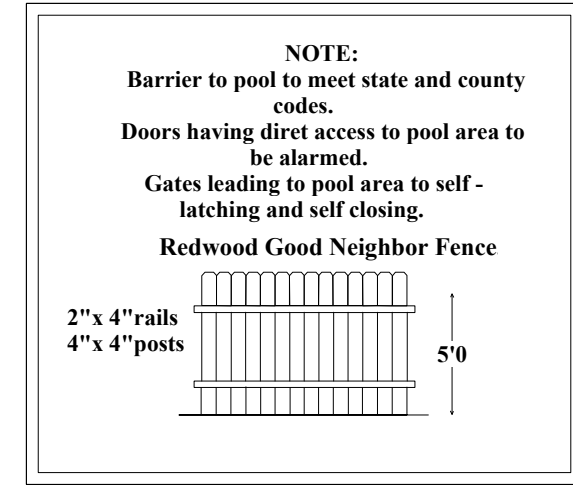

DRAWN BY: **Les.Bedingfield.**

DATE: **10-01-2015.**